

Motor Control & Protection

JR28F Thermal Overload Relay



General

JR28F series thermal overload relays provide overload and phase loss protection for AC motors. They are suitable for 50/60 Hz circuits, rated voltage up to 690 V, and rated current from 51 A to 630 A, for 8-hour duty or continuous duty.

These relays feature phase-loss protection, ON/OFF indication, temperature compensation, and manual/automatic reset functions.

Standards: IEC 60947-4-1

Type designation

JR28F-400 259- 414A

Thermal Overload Relay	Design Serial Number	Frame	Adjustable Current Range
JR	28F	400/630	259-414A
Thermal Overload Relay	Design Serial Number	400/630	51-81A 62-99A 84-135A 124-198A 146-234A 174-279A 208-333A 259-414A 321-513A 394-630A

Operating condition

1. Ambient temperature: -5°C~+40°C
2. Relative humidity: ≤50% at 40°C; ≤90% at 20°C
3. Altitude: ≤2000m
4. Environmental conditions: no harmful gases and vapors, no conductive or explosive dust, no severe mechanical vibration

Motor Control & Protection

JR28F Thermal Overload Relay

Technical data

Model	Rated Insulation Voltage Ui	Setting Current Adjustment Range (A)	Matching Contactor CJX2-F Series
JR28F-400	660	51-81	CJX2-F115 CJX2-F150
		62-99	
		84-135	
		124-198	CJX2-F185
		146-234	CJX2-F225 CJX2-F265 CJX2-F330
		174-279	
		208-333	
		259-414	CJX2-F400
JR28F-630	660	321-513	CJX2-F500
		394-630	CJX2-F630

Model	Rated Insulation Voltage Ui	Setting Current Adjustment Range (A)	Matching Contactor YCC7/CJX2s Series
JR28F-400	660	51-81	YCC7/CJX2s-115 YCC7/CJX2s-150 YCC7/CJX2s-170 YCC7/CJX2s-120 YCC7/CJX2s-160
		62-99	
		84-135	
		124-198	
		124-198	
		146-234	
		174-279	
		124-198	YCC7/CJX2s-330 YCC7/CJX2s-400 YCC7/CJX2s-500
		146-234	
		174-279	
		208-333	
		259-414	
		JR28F-630	660
394-630			

Motor Control & Protection

JR28F Thermal Overload Relay

Structural Characteristics and Working Principle

1. The setting current is continuously adjustable;
2. Equipped with temperature compensation, with an ambient temperature upper limit of +40°C and a lower limit of -5°C;
3. Both auxiliary circuit terminals and main circuit outgoing terminals are equipped with protective covers;
4. Equipped with action indication, manual reset device and stop function;
5. Equipped with a locking device to prevent misoperation;
6. Normally open and normally closed auxiliary contacts are insulated and separated.

Working Principle

The thermal overload relay adopts a front-rear overall structure, and its main components include: heating elements, auxiliary contacts, action system and reset mechanism. The heating elements and transformers are connected to the main circuit, through which the current of the motor flows. When the motor is overloaded, the main bimetallic strip is heated to the action temperature, causing the thermal overload relay to act, the normally closed contacts open, and the contactor cuts off the main circuit. The action time of the thermal overload relay changes with the magnitude of the overload current according to an inverse time-limit relationship. The typical working principle diagram of the thermal overload relay is shown in Figure 1. If it is used for overload protection in AC single-phase or DC circuits, the three-phase heating elements must be connected in series.

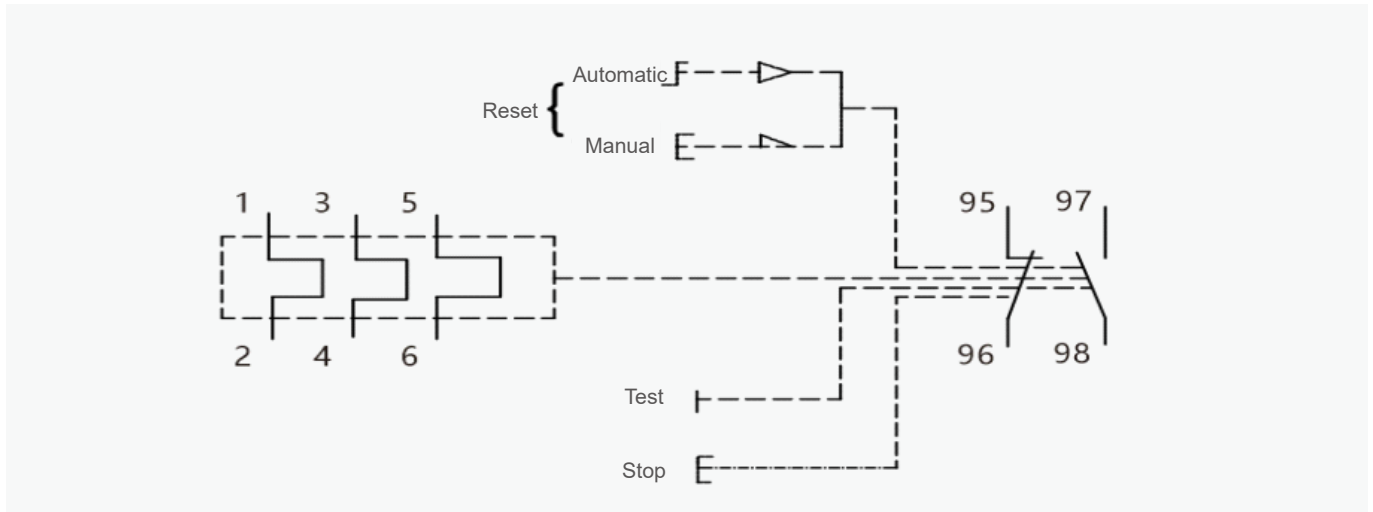

Motor Control & Protection

JR28F Thermal Overload Relay

Basic Parameters of Auxiliary Contacts

Usage Category	Rated Frequency (Hz)	Conventional Free Air Thermal Current I_{th} (A)		Rated Insulation Voltage U_i (V)	Rated Working Voltage U_e (V)	Rated Working Current I_e (A)
		Normally Open	Normally Closed			
AC-15	50	5	5	380	220	2.73
DC-13					380	1.58
					220	0.21
					110	0.46

Operating Characteristics When Each Phase Load is Balanced

No.	Setting Current Multiple	Operating Time	Initial Condition	Ambient Air Temperature
1	1.05	No action within 2h	Starting from cold state	20±5°C
2	1.2	Action within 2h	Starting from hot state (after test No.1)	
3	1.5	Action within 2min		
4	7.2	2s<T _p ≤10s	Starting from cold state	

Operating Characteristics When Each Phase Load is Unbalanced (Phase Loss)

No.	Setting Current Multiple		Operating Time	Initial Condition	Ambient Air Temperature
	Any Two Phases	The Other Phase			
1	1	0.9	No action within 2h	Starting from cold state	20±5°C
2	1.15	0	Action within 2h	Starting from hot state (after test No.1)	

Temperature Compensation Performance

No.	Setting Current Multiple	Operating Time	Initial Condition	Ambient Air Temperature
1	1	>2h	Starting from cold state	+40°C
2	1.2	<2h	Starting from hot state (after test No.1)	
3	1.05	>2h	Starting from cold state	-5°C
4	1.3	<2h	Starting from hot state (after test No.3)	

1. The manual reset time after the thermal overload relay trips shall not exceed 5 minutes, and the automatic reset time shall not exceed 10 minutes.

2. The power frequency withstand voltage of the thermal overload relay is 2500V for the main circuit and 2000V for the auxiliary circuit.

Motor Control & Protection

JR28F Thermal Overload Relay

Overall and mounting dimensions(mm)

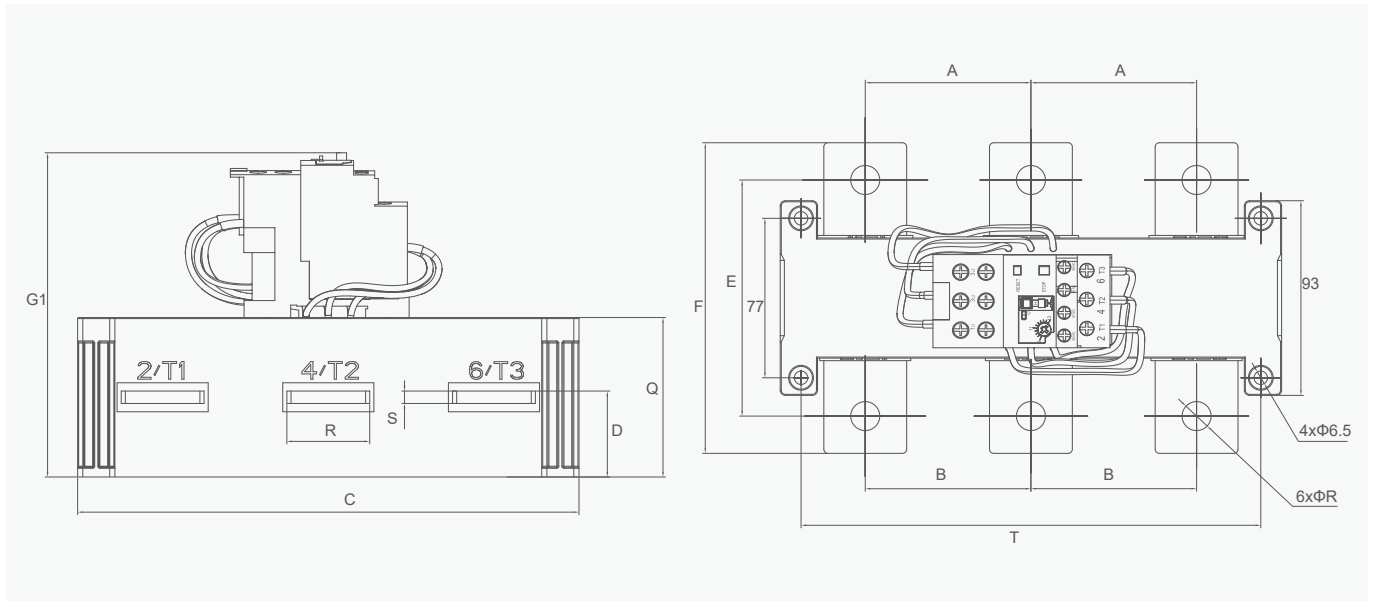

Specification Model	Rated Current (A)	A	B	C	D	E	F	G1	G2	P	Q	R	S	T	Mounting Base
JR28F-400	51-81	34.8	55.5	182	32	119	141	144	156	9	63	18	3	164	LAES1
	62-99	34.8	55.5	182	32	119	141	144	156	9	63	18	3	164	
	84-135	34.8	55.5	182	32	119	141	144	156	9	63	20	3	164	
	124-198	40	55.5	182	32	109	131	144	156	10	63	25	3	164	
	146-234	48	55.5	182	32	109	134	144	156	12	63	25	3	164	
	174-279	48	55.5	182	32.5	109	134	144	156	12	63	25	3	164	
	208-333	48	55.5	182	32.5	109	134	144	156	12	63	25	4	164	
	259-414	48	55.5	182	32.5	109	134	144	156	12	63	25	4	164	
JR28F-630	321-513	55	76	242	43	110	140	158	170	14	77	30	5	222	LAES2
	394-630	80	80	242	43.5	114	150	158	156	14	77	40	6	222	

For the selection of connecting wires for the main circuit of the thermal overload relay, the screws of the connecting wires shall be tightened without looseness, and the tightness shall be checked regularly during use; otherwise, the thermal overload relay may lose its protective effect.

Current Range (A)	Standard Cross-Sectional Area of Wire (mm ²)	Wire Length Between Two Terminals (m)
80<I≤125	50	2.0
100<I≤160	70	2.0
125<I≤200	95	2.0